

The Formwork Experts.

Staxo/d2 winch

Art. n°: 582779000, 581780000 | 1994 models onward

Original Operating Instructions

Please retain for future reference

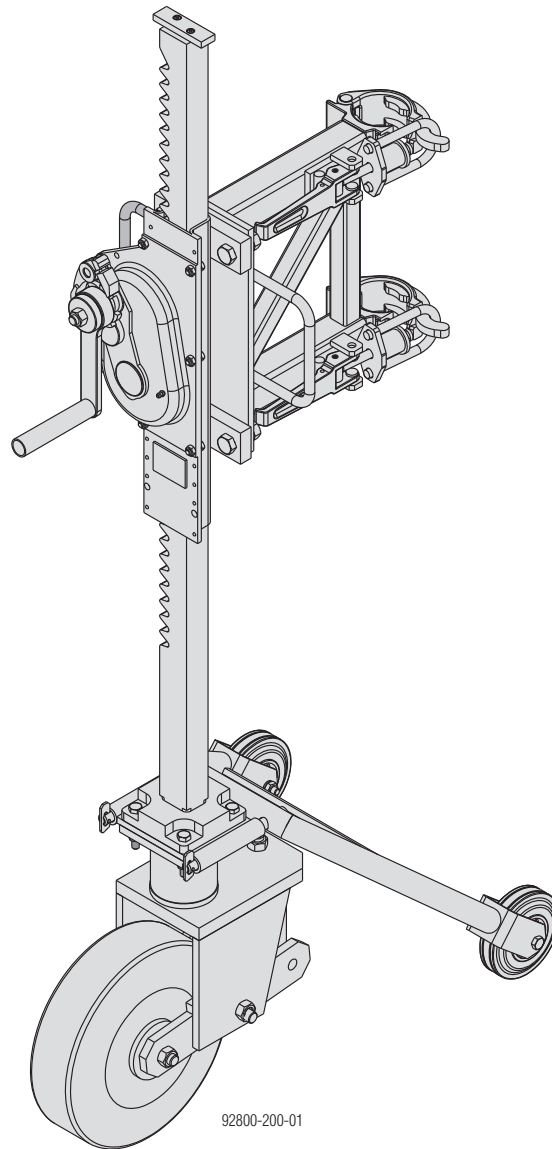

92800-200-01

Basic drawings of product

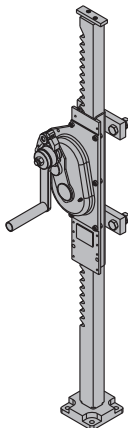
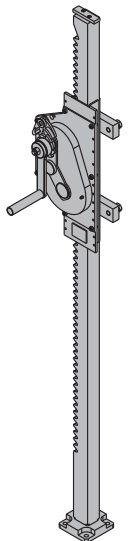
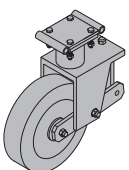
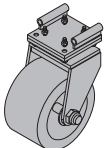
<p>Winch 70 Art. n° 582779000 Max. load: 1000 kg Lifting height 700 mm</p>  <p style="text-align: right;">CE</p>	<p>Winch 125 Art. n° 582780000 Max. load: 1500 kg Lifting height 1250 mm</p>  <p style="text-align: right;">CE</p>
<p>Solid-tyre wheel Art. n° 582573000 Max. load: 1000 kg</p> 	<p>Heavy-duty wheel 15 kN Art. n° 582575000 Max. load: 1500 kg</p> 

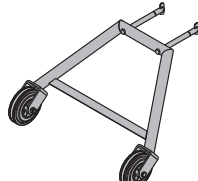
<p>Double wheeled transporter Art. n° 582558000</p> 
--

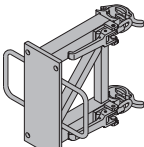
<p>Staxo/d2 adapter frame Art. n° 582781000</p> 
--

Ready-assembled winches

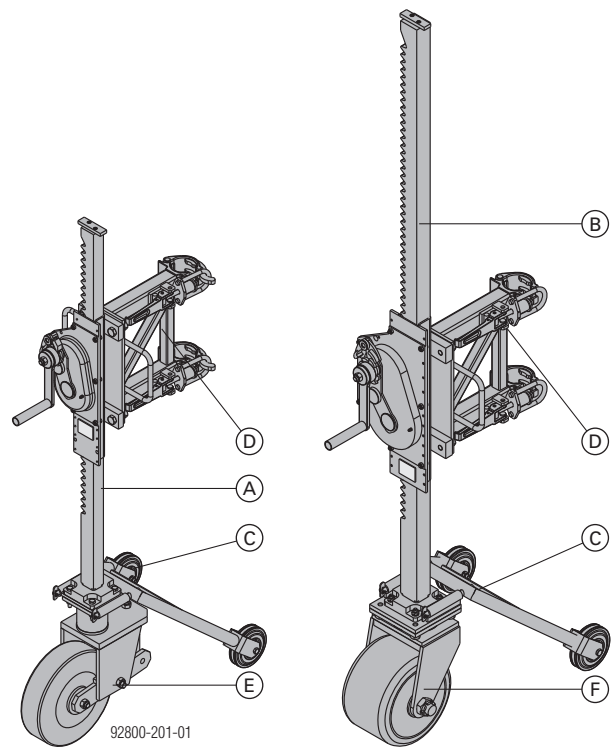

- A** Winch 70
- B** Winch 125
- C** Double wheeled transporter
- D** Staxo/d2 adapter frame
- E** Solid-tyre wheel
- F** Heavy-duty wheel 15 kN

Intended use

The winches are be used for mechanical lowering, raising and wheeling of Doka load-bearing towers Staxo or d2 (intended use).



NOTICE

- Other use or use not in conformity with that stated above is non-intended use and requires the prior written approval of the Doka company!
- Repositioning load-bearing towers of other manufacturers is prohibited!

Maintenance & inspection

- Repairs may only be carried out by the manufacturer!
- Doka accepts no liability for products that have been altered!

Before every use

- ▶ Check for any signs of damage or visible deformation.



Lifting accessories that do not meet the following criteria must be withdrawn from use immediately:

- Crack-free and notch-free welds.
- No deformation.
- Rating plate must be in place and clearly legible

At regular intervals

- ▶ Grease the (extended) pinion-rack once a month – more often if subjected to heavy use.
- ▶ Refill the gear reduction unit with new grease once a year.



NOTICE

With the safety crank-handle, make sure that no grease gets onto the brake disc.

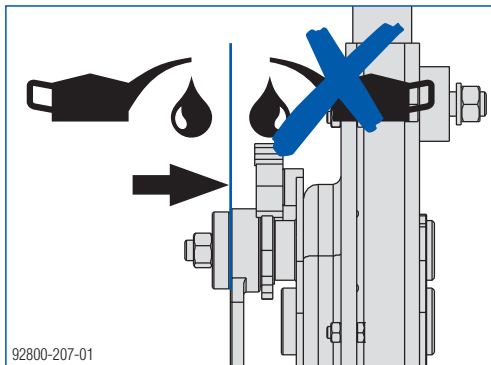

- Inspection of lifting accessories must be performed at regular intervals by an **expert** in conformity with **national statutory provisions**. Unless otherwise stipulated, such inspection must be carried out **at least once a year**.

Storage

- Store lifting accessories in a dry and well ventilated place, protected from the weather and from all corrosive substances.

How to use

- ▶ Wheel the winch up to the load-bearing tower (this must no longer be under load).
- ▶ Set the correct adapter position by turning the handle until the winch reaches the required lowering height.

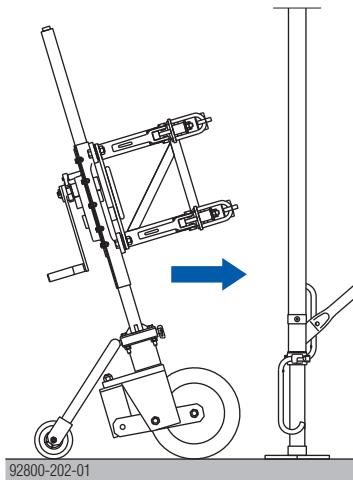

- ▶ To raise the load-bearing tower, turn the crank-handle clockwise.
- ▶ To lower it, turn the handle anti-clockwise.

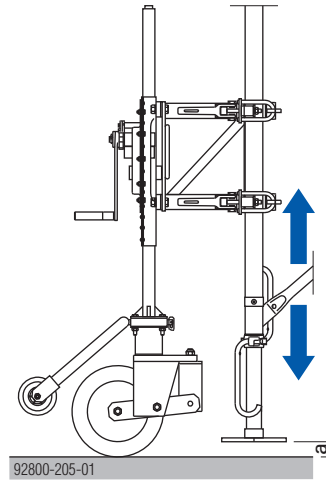

a ... max. 50 mm

- ▶ Using both quick-acting couplings, clamp the winch to the frame, at the height you have just set.

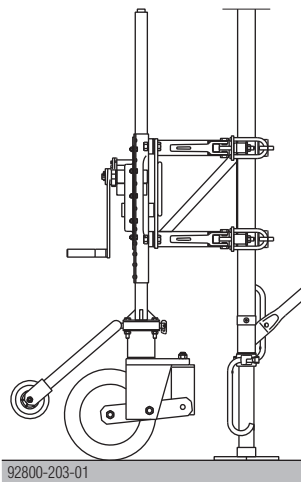

NOTICE

Ensure the best possible clamping effect!

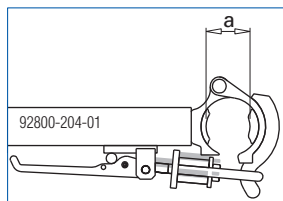

Control dimension 'a' ... 58,0 mm

Make sure that there is the best possible clamping effect on the basic frame. If necessary, use the hexagon nut and tension rod to set the **control-dimension** so that there is zero play.

Travelling the towerframe units

Safety requirements

- 4 winches must be fixed to each towerframe unit that is to be travelled.
- After clamping the winches onto the frames, push the base units up into the towerframe unit and secure them.
Max. distance from floor: 50 mm.
- Max. travel speed: 2 km/h.
- The floor must be stable, firm and sufficiently smooth (e.g. concrete).
- Max. permitted inclination of trackway: 2%
The permissible inclination of the trackway must be determined by statical calculation (risk of overturning, rolling forces).
- Either bridge any openings in the floor with sufficiently strong planking/boards secured so that they cannot slip away to either side, or close off openings with sufficiently strong side railings!
- Special care is needed when travelling across shoulders in the ground (no sharp-edged shoulders, max. shoulder-height 15 mm).
- Keep the travel route clean and free of any obstacles.
- It is forbidden to use any mechanical assistance during the wheeling operation!
- Only travel with pinion-rack retracted as far as possible!
- After the towerframe unit has been travelled, or for longer breaks during the travelling operation, remove the load from the winches so that it cannot be moved accidentally!
- It is forbidden for any third persons to linger in the immediate danger zone!
- It is forbidden for persons to ride on towerframe units while these are being travelled!
- It is only permitted to travel Doka load-bearing towers that have been braced in accordance with the assembly plans and erection rules given in the User Information booklet.
- Before travelling the tower, remove any loose objects from the formwork and scaffold (tools, connector components, residual dirt etc.).

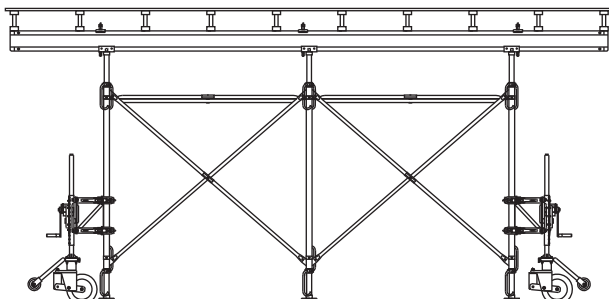

92800-206-01



NOTICE



With standard superstructures, the max. width-to-height ratio of the table+tower is 1:3. A statical check must be performed on custom constructions.



NOTICE

- Exercise caution regarding the risk of overturning (particularly in strong wind).
- Take care to start moving gently, and to exert a constant, uniform pull.

Declaration of conformity

 EC Declaration of Conformity pursuant to EC Directive 2006/42/EC.	
The manufacturer declares that by reason of its conception and design, the following product Winch 70, Art. n° 582779000 Winch 125, Art. n° 582780000 conforms – in the version marketed by ourselves – to the pertinent fundamental health and safety stipulations of the relevant EC Directives.	
The following harmonised Standards were applied: <ul style="list-style-type: none"> ▪ EN ISO 12100:2010 ▪ EN 349:1993+A1:2008 	
Person authorised to compile technical documentation (pursuant to European Directive on Machinery Annex II): Dipl.-Ing. Ludwig Pekarek Josef Umdasch Platz 1 A-3300 Amstetten	
Amstetten, 14.02.2018	Doka GmbH Josef Umdasch Platz 1 A-3300 Amstetten
 	
Dipl.-Ing. Ludwig Pekarek Executive Manager	Dipl.-Ing. Peter Reisinger Authorised Officer, Head of Engineering